

TRU-BOLT®
Genesis
Electronic Deadbolt with Biometric
Touchscreen and Entry Lever Installation

ENGLISH

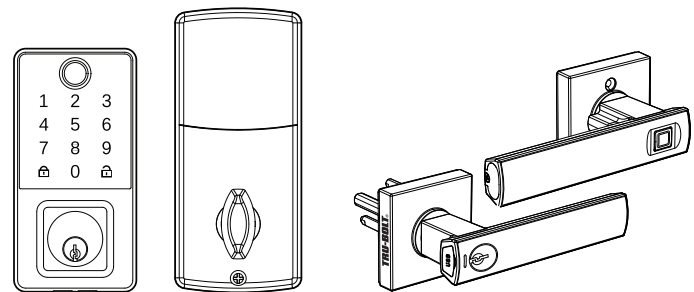

Read this manual carefully before installing and operating!

Important

Use the QR code below for the most up to date instructions:



Tools Needed for Lock Installation:

- Phillips Screwdriver



1 Deadbolt Installation Overview

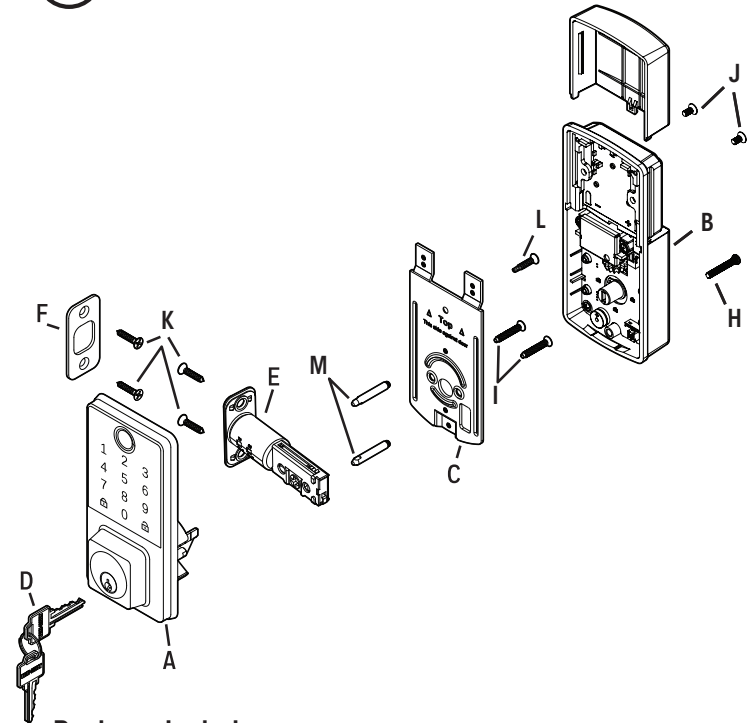

Package Includes:

- | | | |
|------------------------|--------------------|------------------------|
| 1 - Exterior Faceplate | 1 - Strike Plate | 2 - 5/16" Screws |
| 1 - Interior Faceplate | 1 - Mounting Plate | 2 - 1" Screws |
| 1 - User Guide | 1 - Latch | 4 - 3/4" Screws |
| 2 - Keys | 1 - 1 3/8" Screws | 2 - Mounting Post |
| | | 1 - Optional Set Screw |

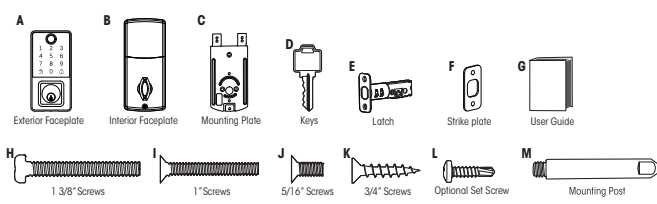

Please carefully check the above list to confirm all items have been received. If any items are missing, please contact Consumer Assistance. (See page for contact information)

Read this manual carefully before installing and operating!

2 Install Enclosed Latch and Strike Plate.
Do not over-tighten latch screws.

NOTE: Do not extend Cylindrical Cover past 2-3/4" (70mm) 2-3/8" position 2-3/4" position

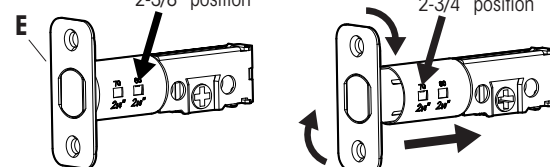

- TO CONVERT FROM 2-3/8" (60mm) BACKSET TO 2-3/4" (70mm) BACKSET:
1. Hold latch with numbers facing forward and thumb pressing on the bolt.
 2. Rotate the cylinder cover clockwise.
 3. Pull and twist the extension plate all the way out.
 4. Rotate the cylinder counter clockwise so that the marking aligns with the 2-3/4" position indicator.

The latch plate on the door needs to be straight and not protruding from door. Make adjustment before installing or this will cause problems with bolt fitting into latch hole.

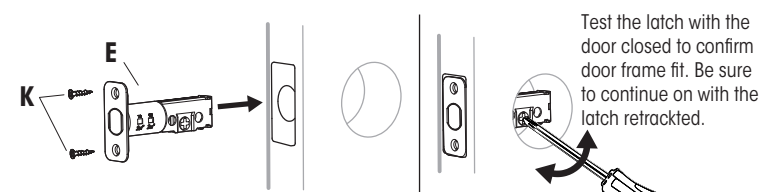

Deadbolt Latch Must Be Retracted During Installation.

Preparation for Interior Assembly.

Remove (J) Screw from inside the battery compartment within the (B) Housing to release the Mounting Plate (C).

Screw Mounting Post (M) into holes on Mounting Plate (C).

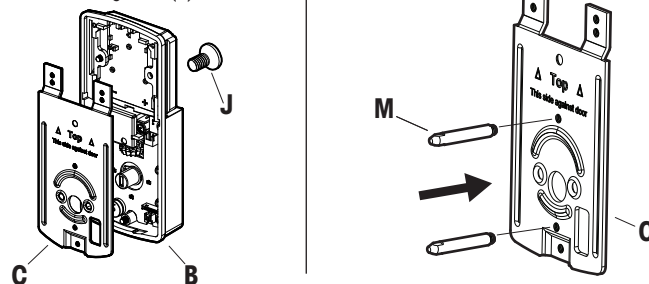

3 Install Exterior Assembly

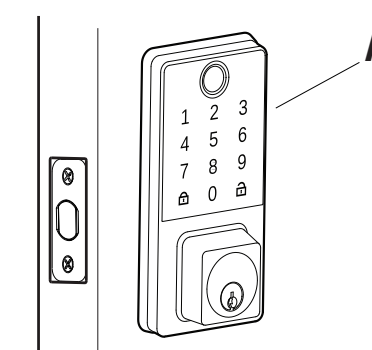

Check that the Rubber Gasket is secured on the Exterior Assembly. Insert the Exterior Assembly onto the door with the tailpiece going through the Deadbolt Latch Set in the **VERTICAL POSITION**.

Route the Control Wire through the door **UNDER** the Deadbolt Latch Set. **Make sure the door is shut, lock and unlock using the key, ensure that the latch is operating smoothly and is aligned properly without scraping the strike plate.** If not, go back to step 2 and ensure you followed the steps

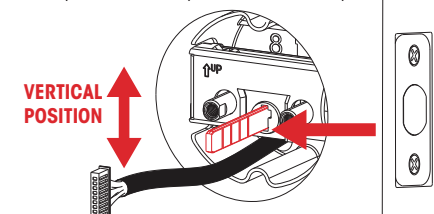

Work with the door open

(L) screw goes into the door to prevent the lock from shifting and is optional.

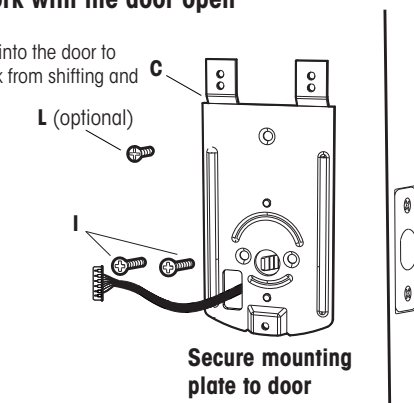

4 Install Interior Assembly

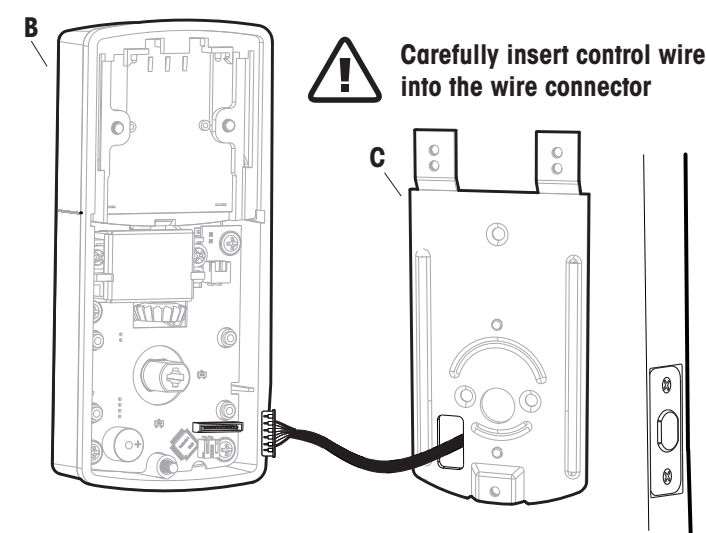

Work with the door open

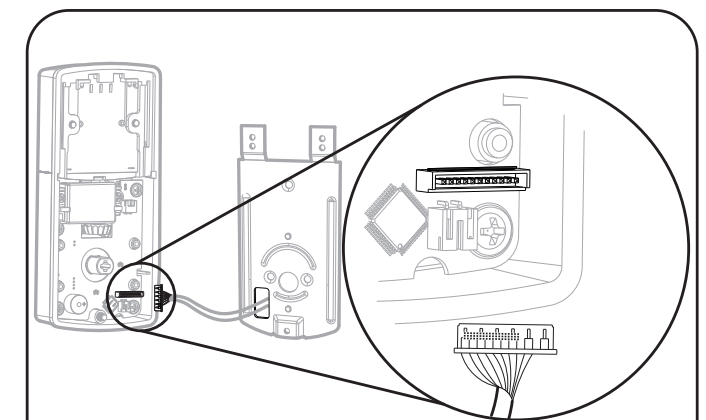

NOTE: Make sure the connector dots line up with the dots on the wire

5 Install Interior Assembly

NOTE: Make sure the Knob is in the correct position. Be careful not to pinch the control wire when assembling

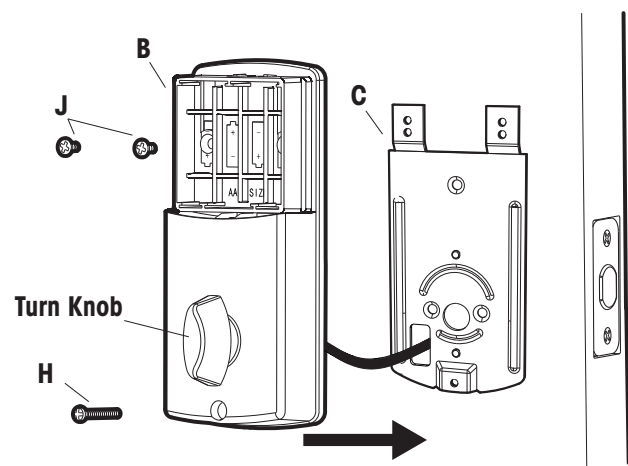

Before Opening Door Let Motor Complete Cycle

6 Install Batteries and Cover

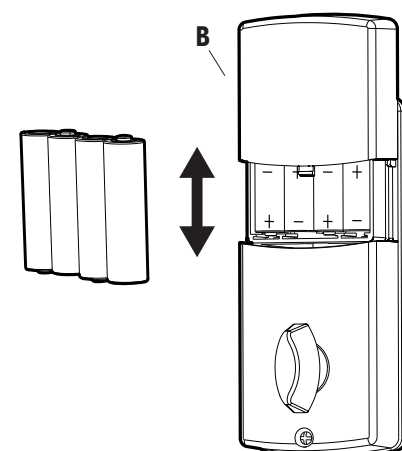

This Electronic lock requires (4) High Quality AA Alkaline batteries. When all 4 batteries are installed in the correct position, you should hear 2 beeps and the keypad will illuminate.

The Lock motor will engage and do a series of locking and unlocking motions in order to automatically determine your door "Handing" (left or right handed door). When completed the lock will beep and the keypad will flash.

NOTE: Do not touch the Keypad until the light turns off. Do not use rechargeable batteries or non-alkaline batteries.

Before Opening Door Let Motor Complete Cycle

7 Testing Operation

Test the lock button with door open

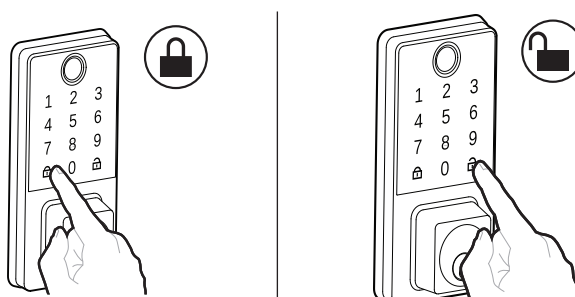

Test unlocking Press 1-2-3-4-*

Lock and unlock using the turn knob, make sure the latch is opening and closing easily. If not, go back to step 2 and ensure you followed the steps

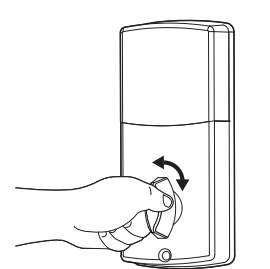

See reverse side for lever installation

Preparing Door

Tools Needed for Door Preparation (if there is no knob hole):

NOTE: Skip this step if your door comes with pre-drilled holes.

- Drill
- 2 1/8" Hole Saw
- 1" Hole Saw
- 3/4" Chisel

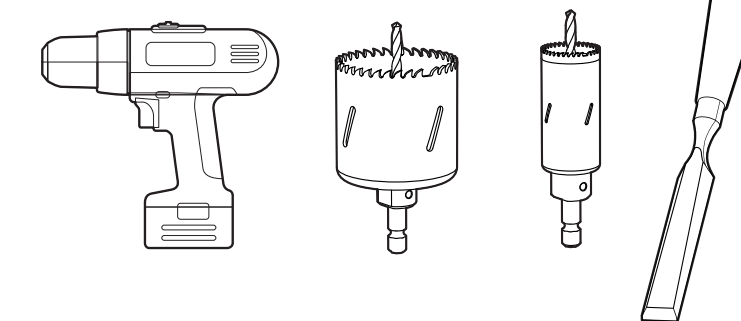

Refer to Template included for Door Prep Instructions

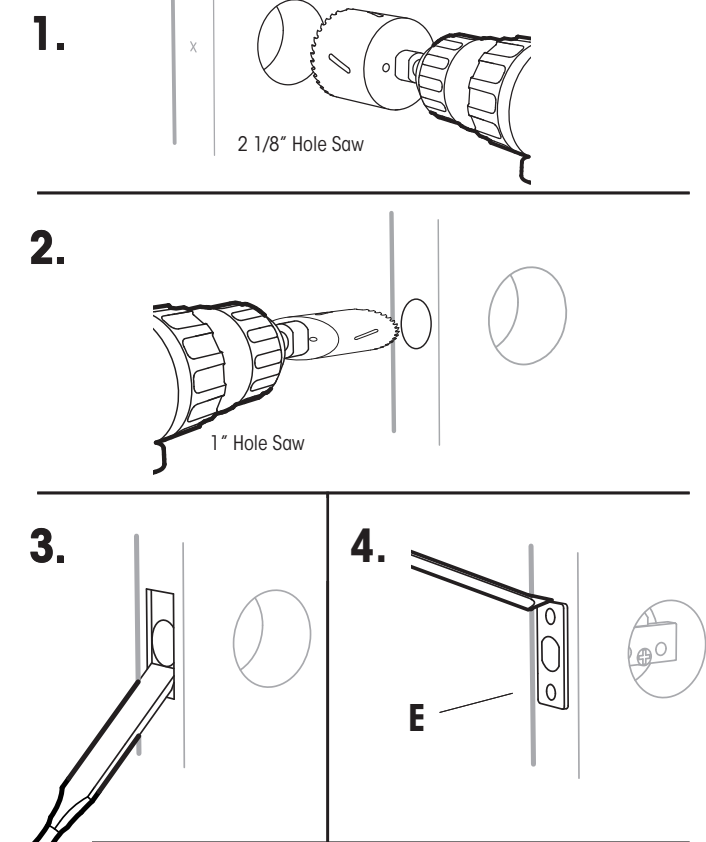
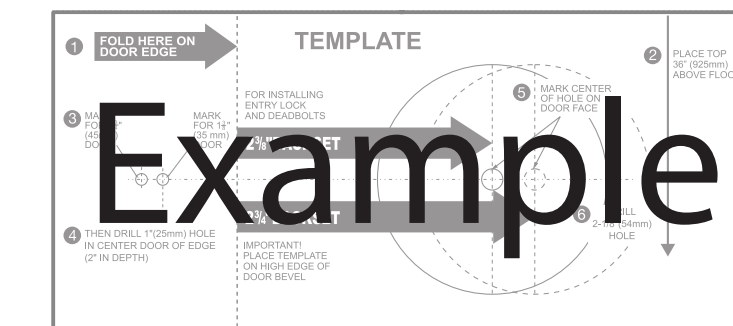

Strike Plate Installation

NOTE: The strike plate on the door frame needs to be straight and not protruding from door frame. Make adjustment before installing or this will cause problems with bolt fitting into latch hole.

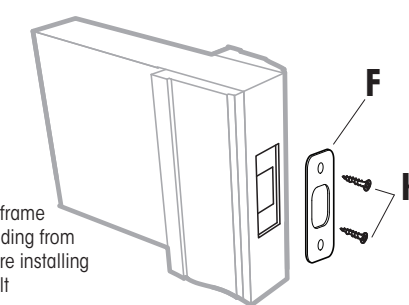

8 Lever Installation Overview

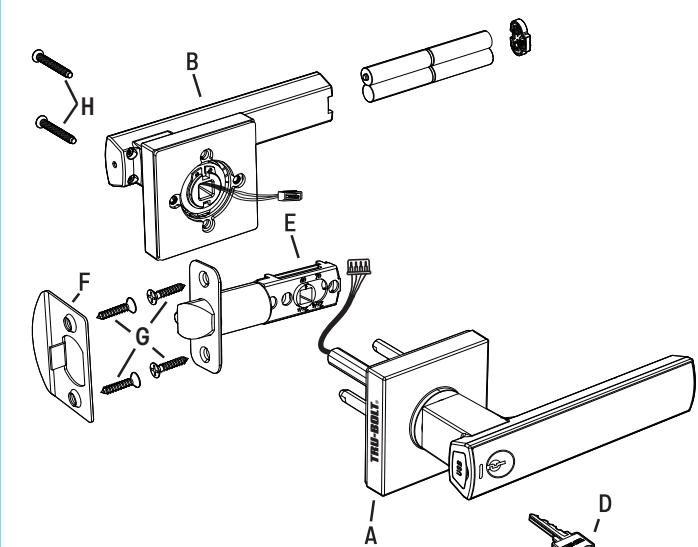

Package Includes:

- 1 - Exterior Assembly
- 1 - Interior Assembly
- 1 - User Guide
- 1 - Strike Plate
- 2 - 1 1/4" Screws
- 1 - Latch
- 4 - 3/4" Screws
- 1 - Reset Pin

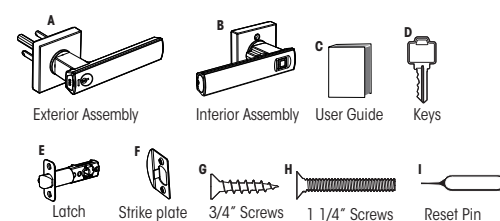

Please carefully check the above list to confirm all items have been received. If any items are missing, please contact Consumer Assistance. (See page for contact information)

Read this manual carefully before installing and operating!

9 Install Exterior Assembly

Determine Door "Handing"

View from outside of door

Left Handed Door

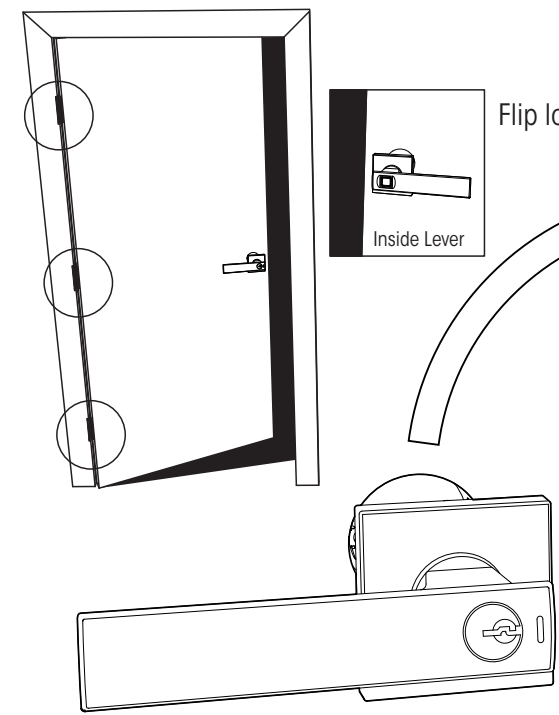

Door hinges will be located on the left when standing outside the door.

Inside lever should point to the right of the hinges.

Right Handed Door

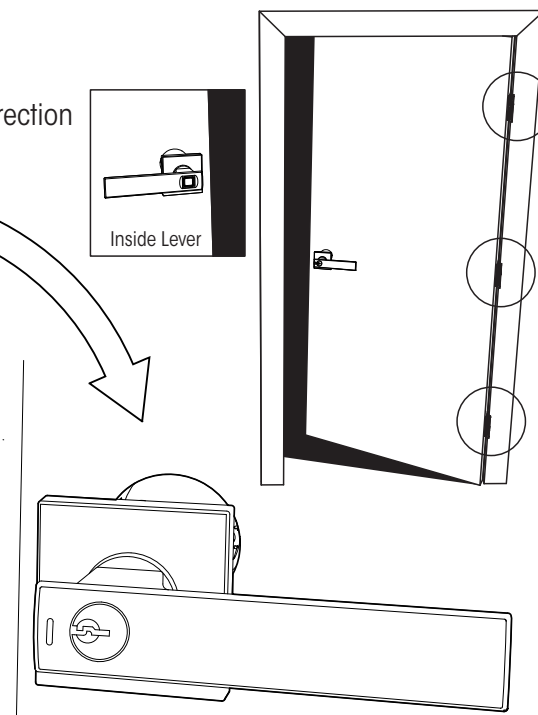

Door hinges will be located on the right when standing outside the door.

Inside lever should point to the left of the hinges.

10 Install Enclosed Latch and Strike Plate

Do not over-tighten latch screws.

NOTE: Do not extend Cylindrical Cover past 2-3/4" (70mm)

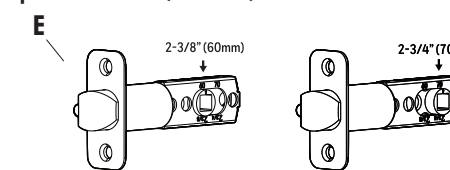

TO CONVERT FROM 2-3/8" (60mm) BACKSET TO 2-3/4" (70mm) BACKSET

1. Hold latch with numbers facing forward and thumb pressing on the latch.
2. Pull or Push the extension plate to the required size.

The latch plate on the door needs to be straight and not protruding from door. Make adjustment before installing or this will cause problems with bolt fitting into latch hole.

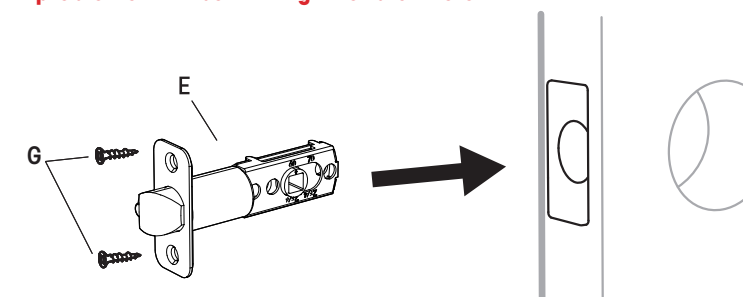

IMPORTANT:
Latch Plunger always faces the inside of the room.

11 Install Interior Assembly

Work with the door open

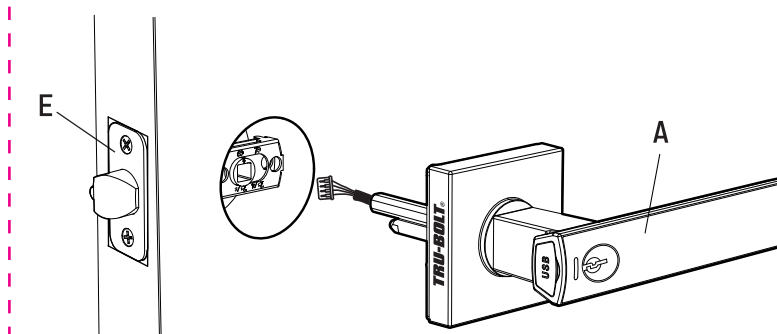

Insert the (A) Exterior Assembly onto the door with control wire going through the (E) latch.

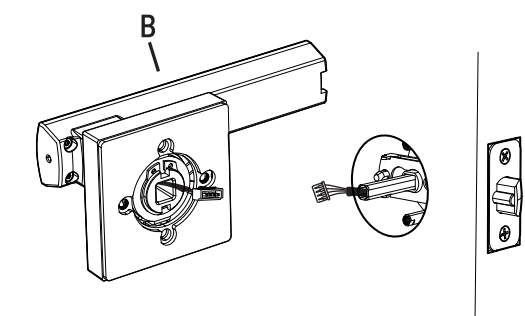

Connect the control wire to the wire connector.

NOTE: Make sure the both sets of dots line up on the wires

12 Install Interior Assembly

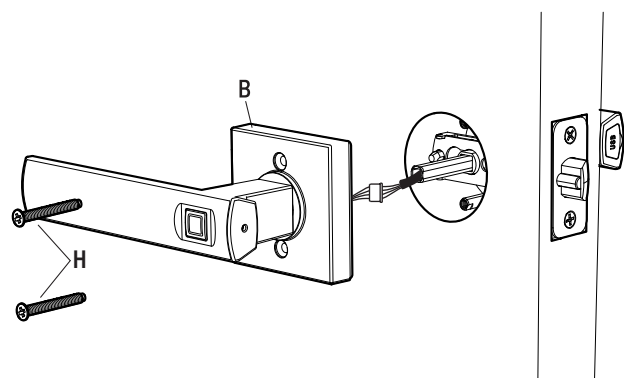

Push excess wire into the (B) interior assembly and insert (H) screws to attach the interior lever.

13 Install Batteries and Cover

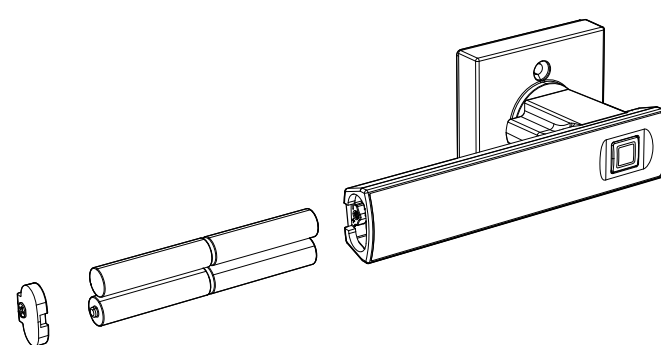

This Electronic lock requires (4) High Quality AAA Alkaline batteries. Tighten battery cover screw. When all 4 batteries are installed in the correct position, you should hear 2 beeps and the thumbprint will illuminate green.

14 Testing Operation

Test the lock with door open

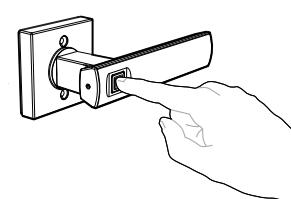

Pressing the button will lock or unlock the lever

15 Low Voltage Alarm

Low voltage alarm is indicated by 7 red flashes when using the fingerprint reader. Change batteries at this time.

TRU-BOLT®
Genesis
Electronic Deadbolt with Biometric
Touchscreen and Entry Lever Programming

ENGLISH

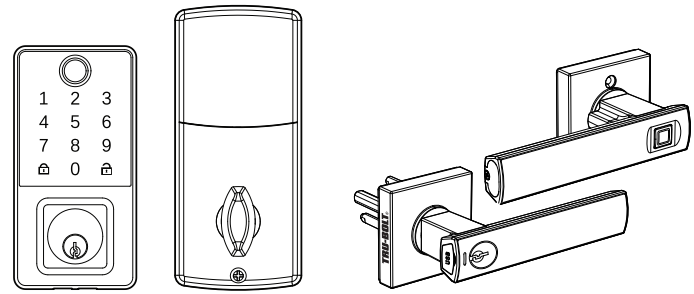

In order to program the lock, select a 6 digit Administrator Code

It is best to write down your Administrator Code prior to step 3. Code cannot be less than 6 digits:

□ □ □ □ □ □



NOTE: Lock must be in the unlock position while programming.
NOTE: Steps 1, 2, and 3 MUST be Completed BEFORE Setting up a Fingerprint. At least 1 fingerprint required.

1 Pairing the Deadbolt and Lever
Lock must be paired before starting Step 2

- Deadbolt:
1) Input Administrator Code (Default 123456), Then Press .
2) Input , Then Press .
3) Input , Then Press . You will hear a short beep and see a blue light.
4) BLE module is turned on for pairing.
Lever:
5) Find the hole on the back side of the interior lever (without keyhole).
6) Press with included pin one time. You will hear one short beep, and the interior lever square will light blue.
7) Paired with Green lights on for both deadbolt and lever.

2 Create A New Administrator Code
Change Admin code and User codes from Factory settings to codes of your choice.

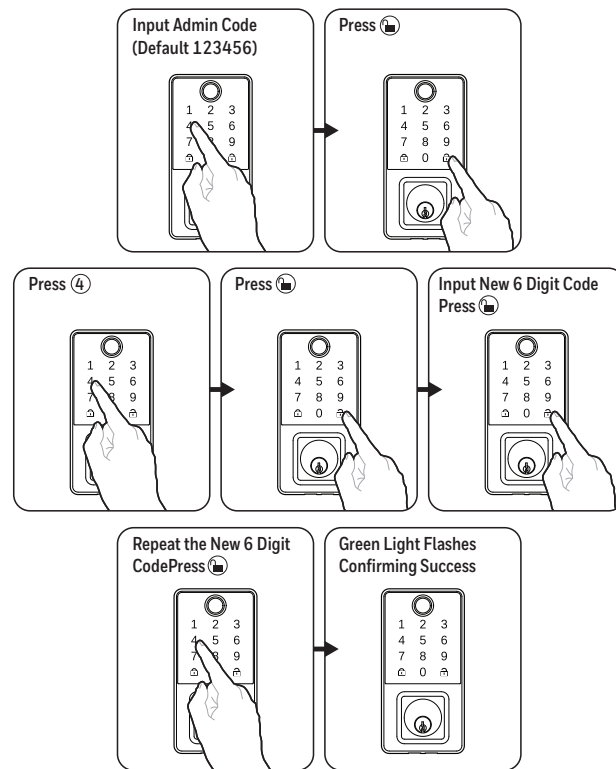

3 Adding a User Code
Set up First User as Administrator.

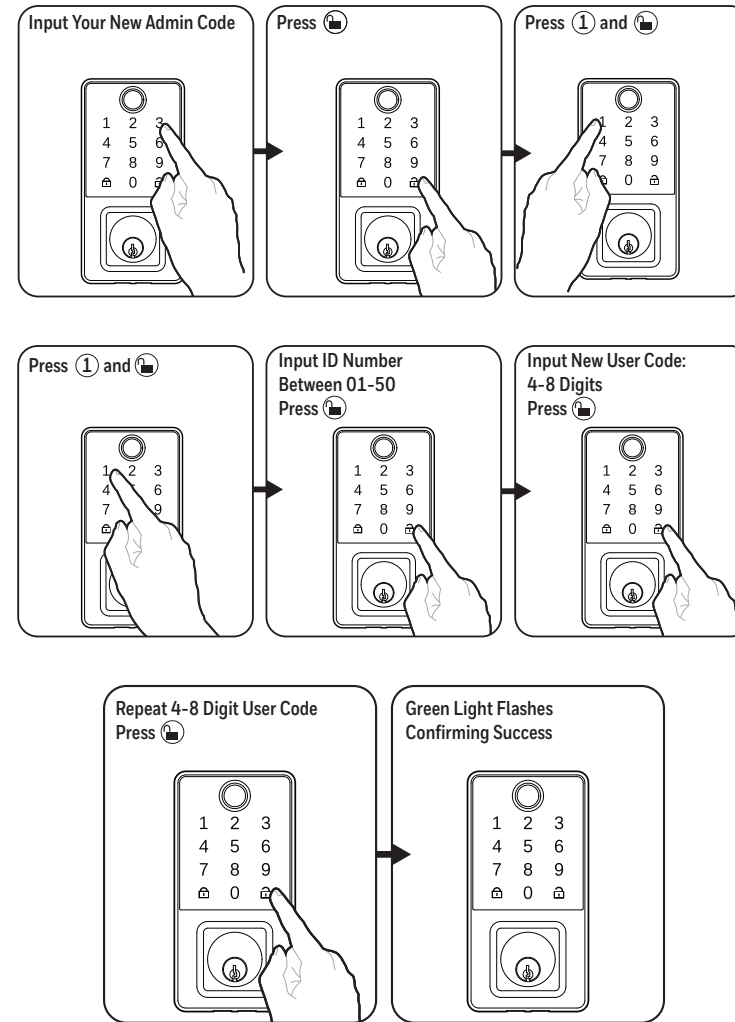

4 Set Up User Fingerprint

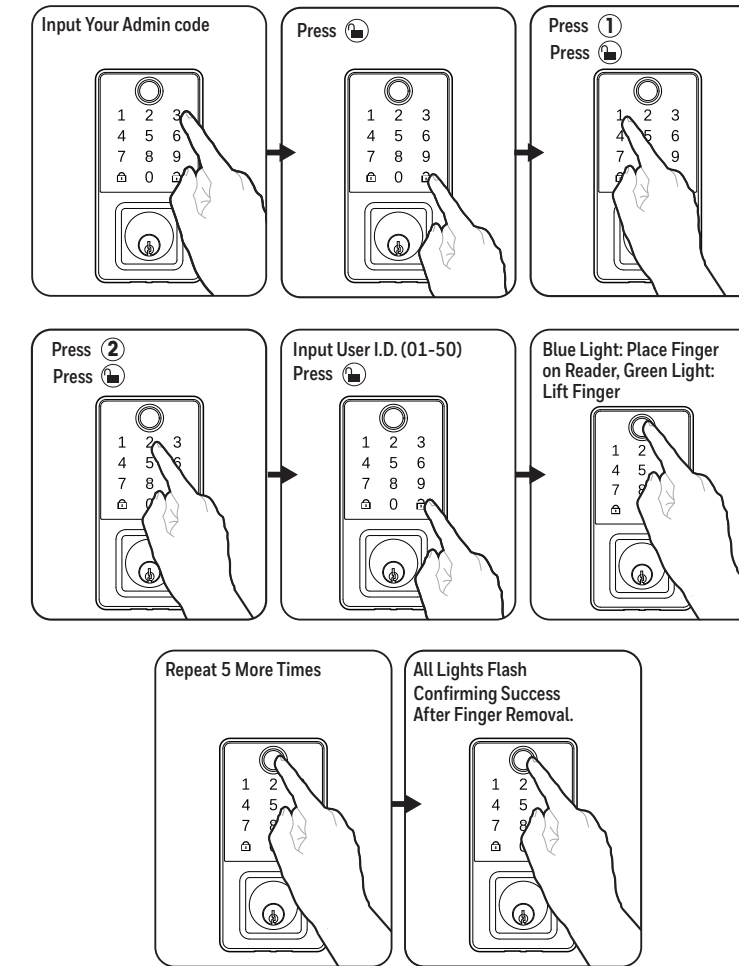

User Passcode Record

User Passcodes Must be 4-6 Digits Long
ID Number 01 Should be Reserved for the Administrator

User Name	User Passcode	Finger Print	ID
_____	_____	_____	01
_____	_____	_____	02
_____	_____	_____	03
_____	_____	_____	04
_____	_____	_____	05
_____	_____	_____	06
_____	_____	_____	07
_____	_____	_____	08
_____	_____	_____	09
_____	_____	_____	10
_____	_____	_____	11
_____	_____	_____	12
_____	_____	_____	13
_____	_____	_____	14
_____	_____	_____	15
_____	_____	_____	16
_____	_____	_____	17
_____	_____	_____	18
_____	_____	_____	19
_____	_____	_____	20
_____	_____	_____	21
_____	_____	_____	22
_____	_____	_____	23
_____	_____	_____	24
_____	_____	_____	25

NOTE: Each Passcode and Fingerprint takes the space of one of the available 50 ID Numbers

5 How to Operate Your New Lock

To Lock your lock - press the lock button.

To Unlock your lock - enter your passcode (not the Admin code or ID number) and wait 5 seconds for lock to Unlock.

OR

Place your finger on the fingerprint reader.

To lock the deadbolt independently: 1 → 1 →

To lock the lever independently: 2 → 2 →

6 Deleting a User Code

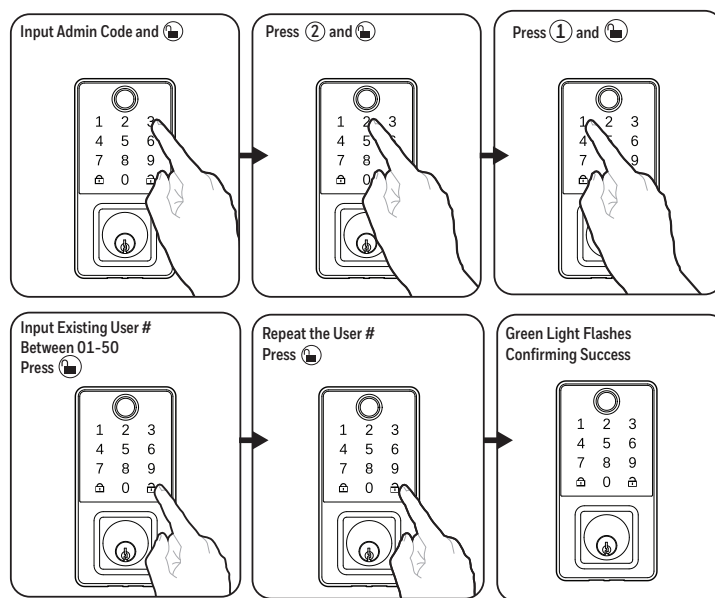

7 Delete User Fingerprint

- 1) Input Administrator Code, Then Press
- 2) Press 2, Then Press
- 3) Press 2, Then Press
- 4) Input the ID (01-50) that will be deleted, Then Press
- 5) Repeat step 4

8 Deleting All User Codes and Fingerprints

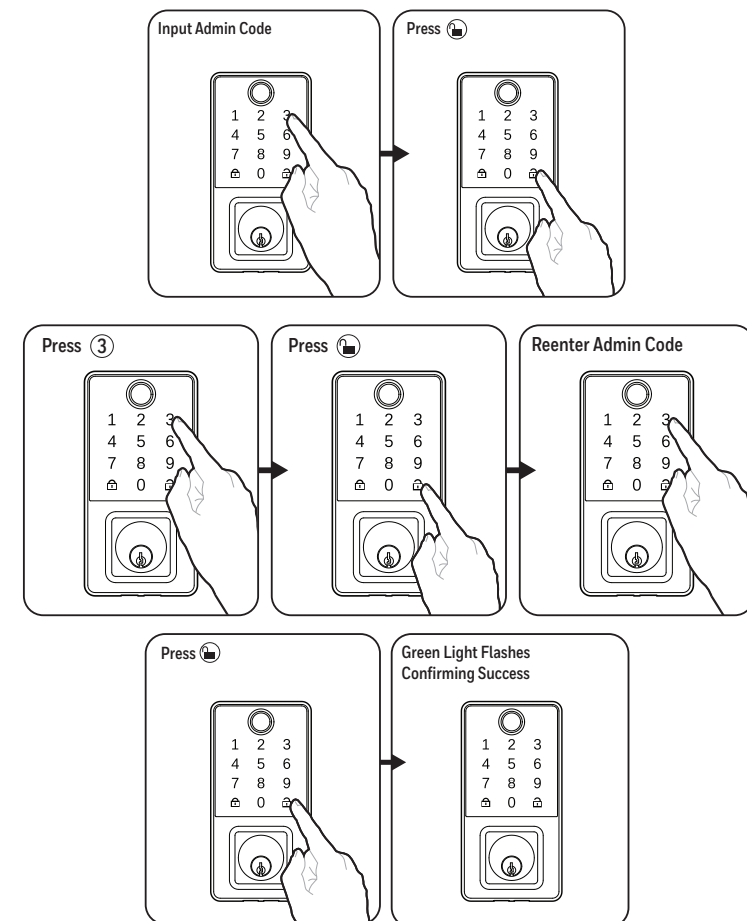

9 Additional Programming Functions

Programming Symbols

- Unlock / Clear / Programming
- Administrator Code

Automatic Lock Function

SET OR CANCEL AUTO LOCK

You can set the lock to automatically lock after each time the lock is opened. Time value range = 20 - 900 seconds, enter the following:

Set Auto Lock: → 5 → → Time Value →

Hear 1 beep and Light Indicator illuminates green.

To cancel Auto Lock set the time to 00, enter the following:

Cancel Time Value Auto Lock: → 5 → → 00 →

Hear 1 beep and Light Indicator illuminates green.

One-time user code: → 7 → → 4-8 digit one-time user code →

Re-enter 4-8 digit one-time user code →

HOW TO PAIR THE LOCKS AFTER BATTERY REPLACEMENT TAKING MORE THAN 20 SECONDS:

If the batteries from the deadbolt are left out of the battery pack for longer than 20 seconds, the deadbolt and lever will no longer be paired and communicate.

To pair the deadbolt and lever, insert batteries into the deadbolt. The bio reader will flash red once, green twice and the deadbolt touchscreen will light up. Place your hand on the lever as seen in the image below. The indicator light on the lever will light up blue then green, the Bio reader on the deadbolt will light up green and the lever will light up red and the door will be locked and the locks will be paired.

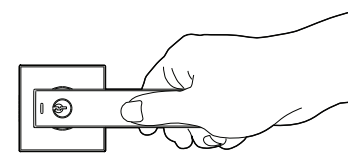

IF PAIRING FAILS, GO BACK TO STEP 1 PAIRING THE DEADBOLT AND LEVER

Vacation Mode

With Vacation Mode enabled, the system enters into low-power consumption mode. During this mode, all buttons and functions will be disabled until they are re-enabled.

ENABLE:

→ 10 → → 1 →

Once the door is locked then vacation mode will be engaged and all buttons and functions will be disabled

DISABLE:

To disable the Vacation Mode, you must press and hold for more than 3 seconds, then input followed by to unlock the door. Vacation Mode is now disabled.

NOTE: If you only press the for more than 3 seconds but do not input , the system will remain in Vacation Mode.

Secure Lock-Out Period

Warning sounds and LED flashes red after 4 incorrect code attempts. Keypad shuts down for 60 seconds.

10 Additional Programming Functions

Sound On And Off

You can "sound off" or turn the "sound on" on your lock by entering the following. (Factory setting is sound on).

→ → 6 → → 1 or 2 →

1 = Sound Off
2 = Sound On

Sound Off (1) - Hear 1 beep and Light Indicator illuminates green.

Sound On (2) - Hear 1 beep and Light Indicator illuminates green.

Restore Factory Settings

To reset the lock to the original factory settings including the Programming Code and all User Codes follow these steps:

1. Remove one battery for 20 seconds.
2. Reinsert the battery and wait for a long and short beep
3. Press 3 times within 3 seconds.
4. The lock will beep and the light indicator will turn green.

Low Battery Warning

Beeps and LED flashes red 7 times. Replace with good quality alkaline batteries.

Note: Removing batteries does not erase active Administrator or User Codes.

Contact Us First! Do Not Return to Store

EMAIL: locks@lewishymaninc.com
WEBSITE: www.frubollocks.info
ADDRESS: Consumer Assistance Dept.
Lewis Hyman, Inc.
860 East Sandhill Avenue
Carson, CA 90746 USA
TELEPHONE: US/Canada 800-860-1677 Ext. 1801 (Toll Free)

Troubleshooting

Issue	Solution
Keypad not function.	<ul style="list-style-type: none"> • Check that all batteries are fresh high quality Alkaline Batteries • Check for proper polarity (+ -) of all batteries • Check that the Control Wire is attached to the Interior Assembly
The Latch is sticking.	<ul style="list-style-type: none"> • Installation screws of the lock may be too tight and have to be loosened • Remove Interior Assembly • Slightly loosen the Mounting Plate screws • Lock and unlock using the Key • Reattach Control Wire and Interior Assembly
No space to store more users.	<ul style="list-style-type: none"> • Delete old user codes or fingerprints
Fingerprint is invalid.	<ul style="list-style-type: none"> • Make sure your fingers and the fingerprint reader are both clean • Keep your finger on the reader until you hear the doorbell • Try using another recorded fingerprint • For consistent failures, delete and reprogram the fingerprint
Latch is not locking in inclement weather.	<ul style="list-style-type: none"> • Push or pull door to direct latch • Re-adjust latch for smoother operations
Admin Code Does not work.	<ul style="list-style-type: none"> • Press numbers slowly and carefully
Fingerprint Does not work.	<ul style="list-style-type: none"> • Hold fingerprint on reader pad longer
Locked out due to wrong code entry	<ul style="list-style-type: none"> • Wait 60 seconds and then try again
Lock is frozen and will not operate	<ul style="list-style-type: none"> • Remove one battery for 30 second to refresh lock
Batteries are dead	<ul style="list-style-type: none"> • Open the lock with Override Access Key and replace batteries
Forgot Admin Code	<ul style="list-style-type: none"> • Reset to factory settings
When temperature is cold	<ul style="list-style-type: none"> • Blow on fingers to warm

See reverse side for lever programming

11 Always Open Mode On or Locked Unless Auto Lock is Engaged

To Lock:

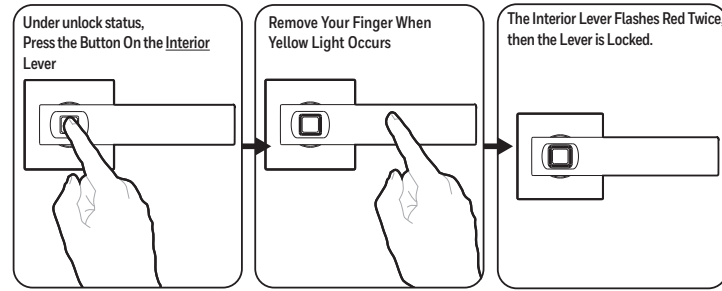

To Unlock:

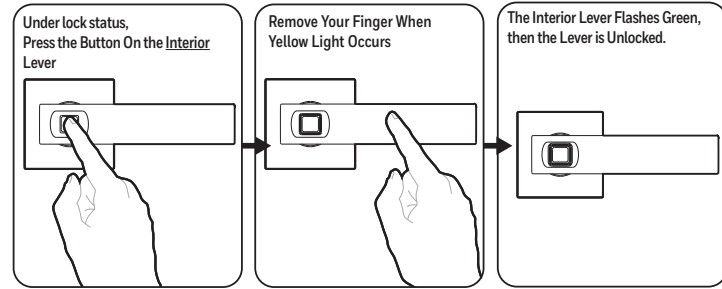

12 Reset to Factory Settings

On the Interior lever, insert included pin in reset slot. A green light will illuminate. Hold the pin for 5 seconds, remove once one beep is heard. The green light will flash 3 times, then one long beep with green light on the exterior lever indicator to confirm success.

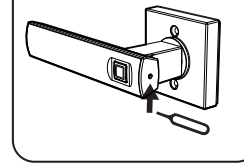

13 Sound And Light

Low-Voltage Alarm: Place any finger on the biometric reader, there will be 7 short beeps with 7 red light flashes, followed by a green light.

During setting mode: Blue light on exterior lever

Correct setting and correct finger recognition: Long beep with green light on

Setting confirmation: Short beep with green light on

Incorrect setting and incorrect finger recognition: 2 short beeps with 2 red light flashes

4 incorrect fingerprint attempts: System is locked for 60 seconds.

Contact Us First! Do Not Return to Store

EMAIL: locks@lewishymaninc.com
 WEBSITE: www.truboltlocks.info
 ADDRESS: Consumer Assistance Dept.
 Lewis Hyman, Inc.
 860 East Sandhill Avenue
 Carson, CA 90746 USA
 TELEPHONE: US/Canada 800-860-1677 Ext. 1801 (Toll Free)

Limited 1-Year Electronic Warranty - Limited Lifetime Mechanical and Finish Warranty
 This Tru-Bolt® product comes with a 1-Year Limited Warranty on Electronic Parts and a Limited Lifetime Mechanical and Finish Warranty against defects in materials and workmanship under normal use to the original residential user. Proof of purchase and ownership is required for the warranty to be in effect. This warranty is non transferable and applies to the original purchaser only, as long as the original purchaser occupies the residential premises upon which the product[s] was originally installed. This warranty DOES NOT COVER removal and reinstallation of product[s], scratches, abrasions, deterioration due to the use of paints, solvents or other chemicals, abuse, misuse, or product[s] used in commercial applications, does not cover any losses, injuries to persons/property or costs, and shipping and freight expenses required to return product[s]. In no event shall Tru-Bolt® be liable for any special, incidental or consequential damages. If this product[s] is considered a consumer product, please be advised that some local and state laws do not allow limitations on incidental or consequential damages or how long an implied warranty lasts, so that the above limitations may not fully apply. Refer to your local laws for your specific rights under this warranty. If there are any problems please call our customer service with any questions or concerns.

Package Warranty:
 Limited Lifetime Mechanical & Finish Warranty:
 This Tru-Bolt® product[s] comes with a 1-Year Limited Warranty on Electronic Parts and a Limited Lifetime Mechanical and Finish Warranty against defects in materials and workmanship under normal use to the original residential user. If there are any problems please call our customer service with any questions or concerns. See installation instructions for full terms and conditions.

DO NOT RETURN TO STORE
 For questions / comments, technical assistance or repair parts - please call toll free at: 1-800-860-1677 x 1801 (M-F 7am-5pm PST)

Don't forget to register your lock at: Truboltlocks.info for updates.